

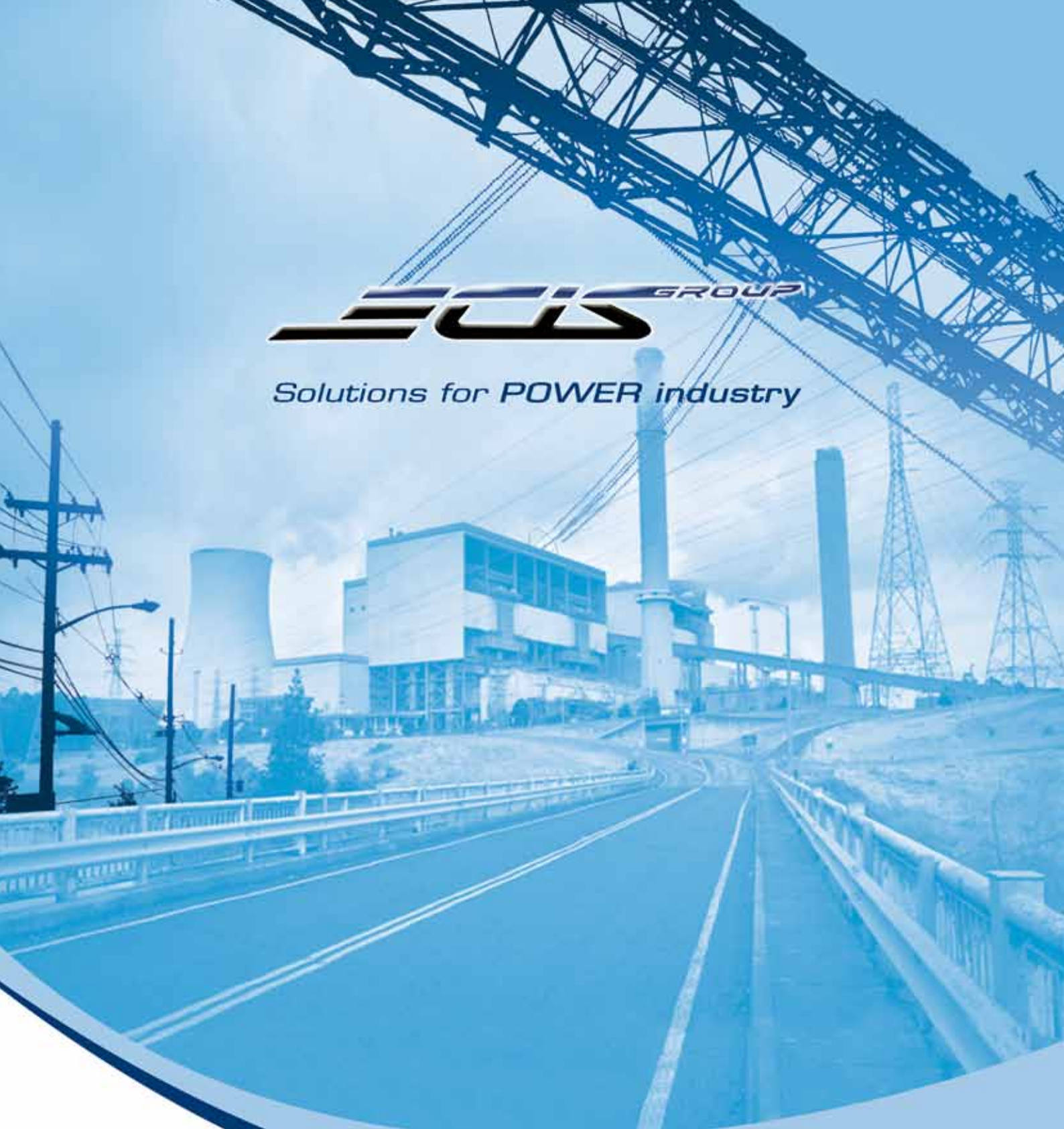

*Solutions for POWER industry*



**POWER**

# La presenza di **ECISGROUP** nei SITI PRODUTTIVI

**ECISGROUP** collabora direttamente con i siti produttivi fornendo servizi e materiali, e con oltre 30 anni di esperienza garantisce eccellenza e competenza in diversi campi di attività. La flessibilità di **ECISGROUP** permette di rispondere velocemente alle necessità dell'impianto, mantenendo i costi contenuti a quanto realmente necessario.

## Servizi

- Ingegneria di processo e specialistica polidisciplinare: base e dettaglio per migliorie e modifiche
- Analisi del rischio di processo: HAZID, HAZOP, LOPA, SIL analysis. Verifiche di adeguatezza della protezioni esistenti.
- Manutenzione e messa a punto dei sistemi di automazione e controllo. Miglioramento della stabilità di conduzione attraverso il tuning e/o la configurazione ottimale. Valutazione delle performance.
- Sostituzione di sistemi di strumentazione ed automazione obsoleti. Bulldozing.
- Certificazione e manutenzione rivelazione incendio
- Sistemi di controllo avanzato su DCS o multi-variabili ed ottimizzazione in tempo reale
- Sistemi ed applicazioni di gestione degli allarmi (attivazione, inibizione, first-out)
- Attività di supervisione e montaggi di strumentazione, di automazione ed elettrici
- Manutenzione, servizi tecnologici avanzati, troubleshooting (es. problemi di cavitazione, analisi del rumore, etc.)
- Pianificazione di dettaglio e supervisione

delle attività in fermata (piping, meccaniche, strumentazione, etc.). Precommissioning, commissioning, avviamento.

- Training per operatori e personale di manutenzione

## CENTRALI A CICLO COMBINATO

Le centrali a ciclo combinato gas/vapore consistono nell'accoppiamento tra un turbogas e un ciclo a vapor d'acqua, in cui il calore entrante nel ciclo a vapore è ottenuto per recupero termico effettuato sui fumi uscenti dalla turbina a gas.

Mediante la combinazione di due cicli termodinamici, gli impianti a ciclo combinato permettono di ottimizzare lo sfruttamento dell'energia contenuta nel combustibile (gas naturale).

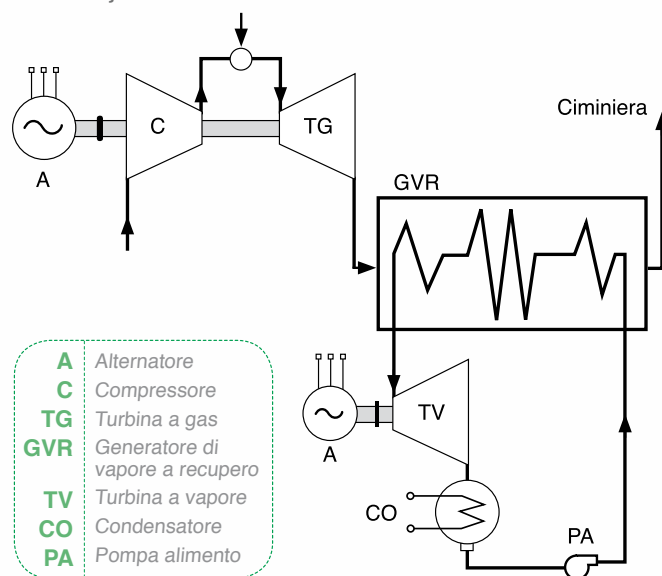

Il contributo di **ECISGROUP** in questi impianti consiste nella realizzazione del sistema di controllo della centrale, e più precisamente:

- Sistemi di controllo su DCS, con controllo diretto dei circuiti condensato - alimento e vapore principale alla turbina e/o verso utilities esterne (per esempio una rete di teleriscaldamento) e delle rampe di pressurizzazione della caldaia.
- Monitoraggio su DCS della caldaia a recupero.
- Controllo diretto oppure interfaccia su DCS dei packages per la gestione degli impianti ausiliari della centrale, come il trattamento del gas naturale, l'aria servizi e strumenti, l'acqua di raffreddamento dei macchinari, l'acqua demineralizzata, la caldaia ausiliaria.
- Comandi e predisposizioni da operatore su DCS per la parte elettrica (apertura interruttori, predisposizione al parallelo ed alla commutazione sbarre)
- Integrazione sul DCS di impianto dei comandi principali delle turbine tramite collegamenti hardwired e/o via OPC.
- Sequenze automatiche di partenza e fermata impianto.
- Sistemi ESD per la protezione dei macchinari principali, con interfaccia su DCS per predisposizioni operatore e monitoraggio impianto.

*Le nostre principali applicazioni nelle centrali a ciclo combinato sono state:*

- *Centrale a ciclo combinato di Pietrafitta Nuova (PG), consegnata nel 2003 ad Enel, potenza elettrica installata di 360 MW nominali, formata da un turbogas Siemens e due turbine a vapore Ansaldo. Il sistema DCS fornito è un Emerson DeltaV con l'utilizzo di tecnologia Foundation Fieldbus.*
- Un'altra applicazione simile alle precedenti è stata:*
- *Centrale a letto fluido del Sulcis sez.2 (CA), consegnata nel 2005 ad Enel, potenza elettrica installata di 340 MW nominali, formata da una caldaia a letto fluido Alstom e da una turbina a vapore Ansaldo. Il sistema DCS fornito è un Emerson DeltaV con l'utilizzo di tecnologia Foundation Fieldbus.*

## ALTRI INTERVENTI SU CENTRALI ELETTRICHE

Si tratta di interventi effettuati su centrali elettriche convenzionali, interventi effettuati per ammodernare oppure ampliare parti di impianto.

- Centrale termoelettrica ENEL di Fusina, lavori di sostituzione del vecchio sistema a blocchi a logica cablata con un nuovo sistema ESD ed ampliamento dello stesso con implementazione di nuove logiche. Il nuovo sistema ESD prevede inoltre un sistema RCE integrato, una interfaccia uomo-macchina in sala manovra principale ed il collegamento verso la rete di Supervisione di Centrale via OPC. Gli interventi sono stati effettuati nel 2009 sulla sez. 4 e nel 2010 sulla sez. 3. Il sistema fornito è un Hima HIQuad.
- Centrale termoelettrica ENEL di Brindisi sud, lavori di sostituzione del sistema di automazione dei letti misti condensato; si tratta di un cabinato contenente armadi a logica cablata e la cui interfaccia è formata da un quadro sinottico montato su una parete del cabinato stesso. Il nuovo sistema prevede l'utilizzo di un DCS con operatività tramite interfaccia video a fronte quadro. I lavori in questo caso comprendono anche le attività di ingegneria dei collegamenti, smantellamento dei vecchi quadri e

riposizionamento dei nuovi, nonché attività di sostituzione di parte della strumentazione in campo. L'intervento è stato effettuato nel 2010 sulla sez. 3. Il sistema fornito è un Invevsys I/A Series.

- Centrale termoelettrica Edipower di Brindisi, lavori di sostituzione del sistema di automazione dell'intero sistema di trattamento del condensato, e cioè il sistema prefiltri (powdex), i letti misti condensato ed i letti misti distillato; si tratta di più cabinati a logica cablata e la cui interfaccia è formata da un quadro sinottico montato su una parete del cabinato stesso. Il nuovo sistema prevede l'utilizzo di un DCS integrato con quello di centrale e con operatività oltre che da sala manovra principale, anche da una sala controllo locale e tramite interfacce video a fronte quadro. I lavori in questo caso comprendono anche le attività di ingegneria dei collegamenti per lo smantellamento dei vecchi quadri ed il riposizionamento dei nuovi, l'intervento è stato effettuato nel 2010 sulle sez. 3 e 4. Il sistema fornito è un Invevsys I/A Series.
- Centrale a ciclo combinato di El Kureimat III (Egitto), consegnata nel 2007, potenza elettrica installata di 750 MW nominali,

formata da due turbogas ed una turbina a vapore. La fornitura comprende l'automazione per la stazione elettrica e per i packages aria compressa, acqua servizi, acqua demi. Il sistema fornito è un Siemens SIMATIC S7-400.

- Centrale termica nella raffineria IES di Mantova, formata da tre caldaie, consegnate fra il 2008 ed il 2010, con una produzione totale di circa 130 ton/h di vapore per i servizi raffineria. La fornitura comprende, per ciascuna caldaia, un sistema BMS per la gestione dei bruciatori ed un sistema DCS per il controllo del circuito acqua / vapore. Il sistema fornito è un Invevsys Trident per la parte BMS, mentre per la parte DCS è un Invevsys I/A Series.
- BAHIA LAS MINAS Repowering project - PANAMA [2009]  
installazione di una caldaia da 120 mw a carbone che alimenta 3 turbine da 40 mw ciascuna, esistenti, e di 3 sistemi DCS. ECISGROUP ha sviluppato per conto SADEMI l'ingegneria funzionale di tutti i sistemi, con esclusione della caldaia partecipando inoltre al FAT dei sistemi di controllo.

*Environmental  
Monitoring Systems  
[CEMS]*

*Chemical Injection  
System*

*Control Room*



# Attività / Materiali fornibili da ECISGROUP:

Environmental Monitoring Systems [CEMS]

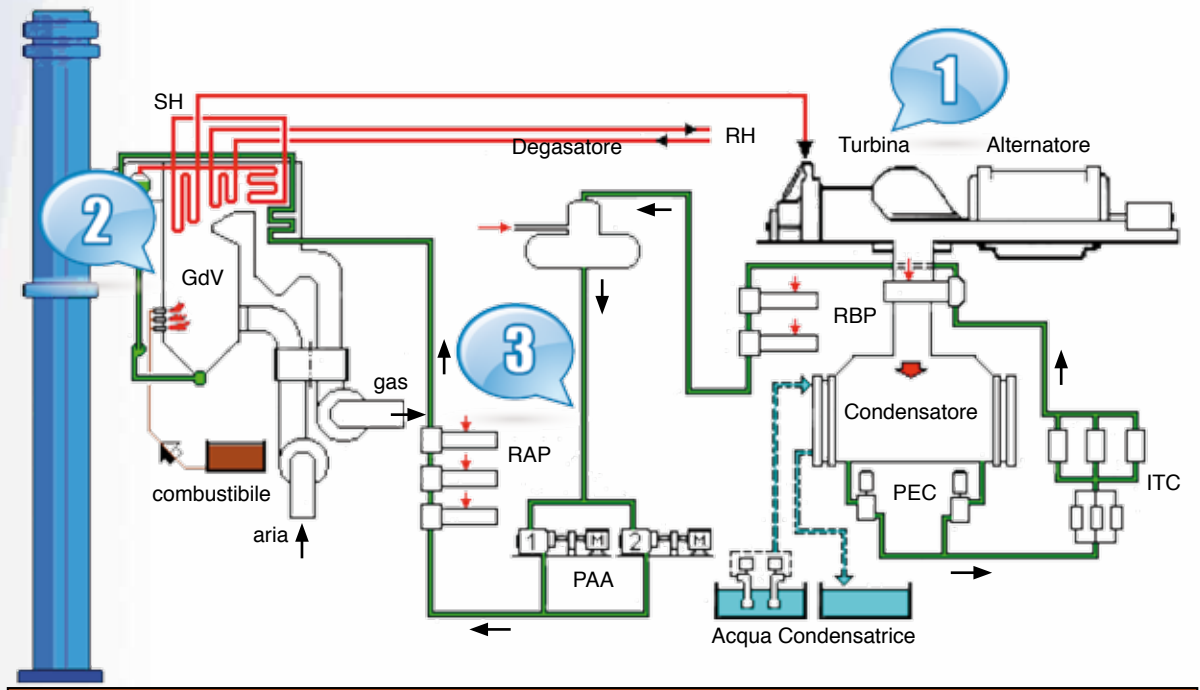

### 1. STEAM TURBINE

- Supervision and vibration control system
- Speed control system
- Electro-instrumentation bulk materials

### 2. BOILER

- BMS / BPS systems
- Blowers control system
- Process and electro-instrumentation plant engineering
- Electro-instrumentation bulk materials
- H<sub>2</sub>O analysis for boilers feed

### 3. THERMAL CYCLE AND AUXILIARY SERVICES

- Process and electro-instrumentation plant engineering
- DCS/PLC process control systems
- IEC 61508 - 61511 certified ESD "Safety" systems
- Condensed treatment control system (Powdex/Mixed Beds)
- Chemicals Injection Skids (Corrosion Inhibitor, Scale Inhibitor - Demulsifier, Pour Point Depressant, Antifoam, Methanol, Glycol, DRAG Reducing Agent)
- Filtration, Measuring, Analysis and Gas Reduction Skids
- Environmental Monitoring Systems [CEMS]
- Electro-instrumentation bulk materials

### ANALYZER SYSTEMS:

- Analyzer Shelter Packages
- Environmental Monitoring Systems (CEMS)
- Sampling Systems
- Sampling Conditioning Systems
- Sampling Conditioning Water Systems
- Oil in Water Monitoring Systems
- Gas Analyzer Systems

### SKIDS & PACKAGES:

- Fuel Gas Train Treatment Skids (ESD, Filtration, Metering, Analysis, Heater, Reducing)
- Gas Pressure Reducing Stations and Final Filtering for Gas Turbine
- Gas Pressure Reducing Stations for Auxiliary Boilers
- Gas Odorizer Systems
- Chemical Dosing Systems for Water
- Steam Cycle and Water (Raw Water treatment, Make-up Water Tower, Desalination, Potabilization, Waste, Biological)
- Chemical Dosing Systems for Cooling Water Towers (Biocide, Biodispersant Sodium, Hypochlorite, Sulphuric acid, Oxygen Scavenger)
- Nitrogen Production Packages: Membrane & PSA
- Instrument and Service Air Packages
- Trucks and Rail Tankers Arm Loading Systems
- Hydrogen Production Packages
- Diesel Power Generation Packages
- Water Treatment Packages (Primary & Secondary Water Biological)
- Fire Fighting Packages



# ECISGROUP

## is present in POWER PLANTS

**ECISGROUP** has direct contact with power plants and supplies services and hardware. With over 30 years of experience, it guarantees excellence and competence in a full range of activities. The flexibility of **ECISGROUP** means it can respond quickly to any requirements, and costs are kept low by providing exactly that which is really required.

### Services

- Process engineering as well as specialised and multidisciplinary engineering skills combine to provide basic and detailed studies for modifications and improvements.
- Risk analysis: HAZID, HAZOP, LOPA, SIL analysis. Verification of the adequacy of existing protection systems.
- Maintenance and optimisation of control and automation systems. Improvement of the stability of the plant through loop tuning and optimisation of the system configuration. Evaluation of the performance.
- Substitution of obsolete instrumentation and control systems. Bulldozing.
- Certification and maintenance of fire detection systems.
- Advanced control systems on DCS, multivariable control and real-time optimisation.
- Alarm handling organisation (activation, inhibition, first-out, SOER).
- Supervision of the installation of instrumentation, control systems and electrical plant.
- Maintenance, advanced technical services,

troubleshooting (e.g. noise analysis, cavitation problems etc.)

- Detailed planning and supervision of the activities during maintenance shutdowns (piping, mechanical, instrumentation etc.). Pre commissioning, commissioning and start-up of plant.
- Training of operators and maintenance personnel.

### COMBINED CYCLE GENERATION

Combined cycle generation (gas/steam) consists of the coupling of a gas turbine with a steam turbine. The waste heat from the exhaust of gas turbine is used to generate steam for the second stage steam turbine. The combined use of both thermodynamic cycles produces an efficient use of the energy contained in the fuel (natural gas).

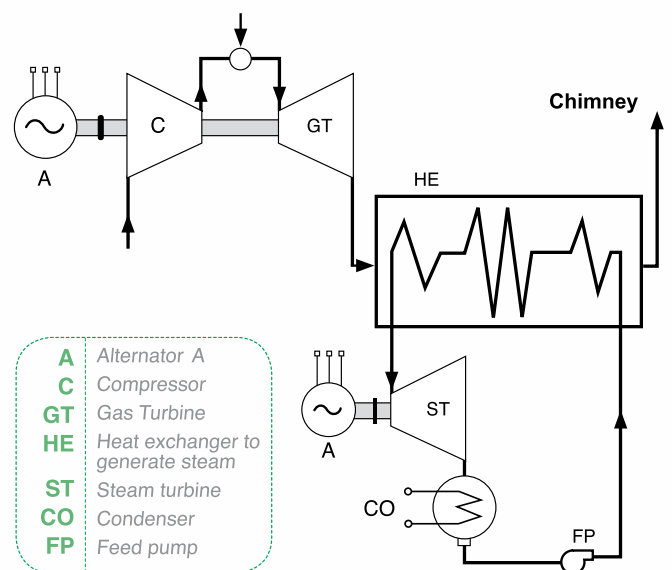

**ECISGROUP** contributes to provide the plant control systems for this type of plant, namely

- DCS control system with direct control of the condensate circuit, feedwater and main steam to the turbine and/or for external utilities (for example, district heating systems) and of the ramp up of the boiler pressure.
- Monitoring of the recovery boiler on the DCS.
- Control of the packages for the auxiliary utilities of the plant, either directly or via the DCS, such as the pre treatment of the natural gas, provision of instrument air, cooling water, demineralised water and auxiliary boilers.
- Commands and presets for the DCS operators for the electrical supply (opening of contactors, predisposition of the switching to parallel and for the bus bars).
- Integration of the turbine controls in the DCS via hardwired connections and/or OPC.
- Automatic start up and shutdown sequences.
- ESD (Emergency ShutDown Systems) for the protection of plant and machinery, with interface with the DCS to enable operator monitoring and supervision of the plant.

*Recent projects for combined cycle plants include:*

- *Combined Cycle Plant at Teverola (CE), Italy, that entered production in 2006 with a nominal generating power of 400MW. The gas and steam turbines were supplied by General Electric. The DCS system was a DeltaV system supplied by Emerson using Foundation Fieldbus technology and Profibus, while the ESD system was a HIMA HiQuad safety PLC.*
- *Combined Cycle Plant at Sesto San Giovanni (MI), Italy, that entered production in 2004 with a nominal generating power of 55MW. The gas turbine was supplied by General Electric and the steam turbine was supplied by Ansaldo. The DCS system was an AC800F supplied by ABB with the*

*Tenore graphic interface also provided by ABB.*

- *Combined Cycle Plant at Pietrafitta Nuova (PG), Italy, that entered production in 2003 for ENEL with a nominal generating power of 4360MW. This has a fluid bed boiler supplied by Alstom and an Ansaldo steam turbine. The DCS system was a DeltaV system supplied by Emerson using Foundation Fieldbus technology.*

*A similar plant to those above is:*

- *Fluid bed power station at Sulcis (CA) in Sardinia that was started up in 2005 for ENEL with a nominal installed electrical generation capacity of 340MW. The fluid bed boiler was supplied by Alstom and the steam turbine by Ansaldo. The DCS system was a DeltaV system supplied by Emerson using Foundation Fieldbus technology*

## OTHER EXAMPLES OF POWER STATION PROJECTS

Described below are some examples of projects undertaken in conventional power stations to modernise or expand the plant.

- *ENEL power station at Fusina (VE), Italy. An obsolete hardwired relay based protection system was replaced and enlarged with a modern HIMA HiQuad ESD system with new logic. The new system integrated a SOER, a Man-Machine interface in the main operations room and the connection towards the station main supervisory system via OPC. The work was performed in 2009 on Section 4 and 2010 on Section 3 of the plant.*
- *ENEL power station at Brindisi South, Brindisi (BR), Italy. The project involved the substitution of the automation system for the condensate mixed beds, that was originally a shelter containing the electrical cabinets and hardwired logic and whose interface is a mimic panel mounted on one wall of the shelter. The new system is a DCS system with a panel display on the front of the cabinet. The project included*

all engineering, the dismantling of the old cabinets and repositioning of the new, as well as the replacement of field instrumentation. The work was performed in 2010. The DCS was the I/A Series supplied by Invensys.

- Edipower power station at Brindisi (BR). The project involved the substitution of the entire control system for the treatment of the condensate, including the prefilters (powdex), the condensate mixed beds and the distillate mixed beds. The old system was hardwired logic with mimic panel and was contained in several shelters. The new system was an Invensys I/A series DCS system integrated with the main control system of the power station with the possibility of control from the operations room, a local control room and a video panel on the front of the cabinet. The work was performed in 2010 and it included the engineering of the project, the dismantling of the old cabinets and repositioning of the new.
- Combined Cycle Power Plant at El Kureimat III, Egypt. This plant was delivered in 2007

with a nominal generating capacity of 750MW. The plant was made up of two gas turbines and one steam turbine. The supply included the automation for the electric plant and the compressed air, service water and demineralised water packages. The control system was a Siemens S7-400 PLC.

- The power plant in the IES refinery. The plant is made up of three boilers with a total production capacity of 130 tons/hour of steam for the refinery. The supply included a Triconex Trident BMS (Burner Management System) for each boiler and an Invensys I/A series DCS system for the control of the water/steam circuit.
- Bahia Las Minas repowering project, Panama (2009). The installation of one coal fired boiler of 120MW that supplies 3 existing steam turbines of 40MW each and 3 DCS systems. ECISGROUP was contracted by SADELMI for the engineering of all systems with the exception only of the boiler, and the factory Acceptance Testing of the control systems.

*Environmental  
Monitoring Systems  
[CEMS]*

*Chemical Injection  
System*

*Control Room*

# Material & Services that ECISGROUP supplies:

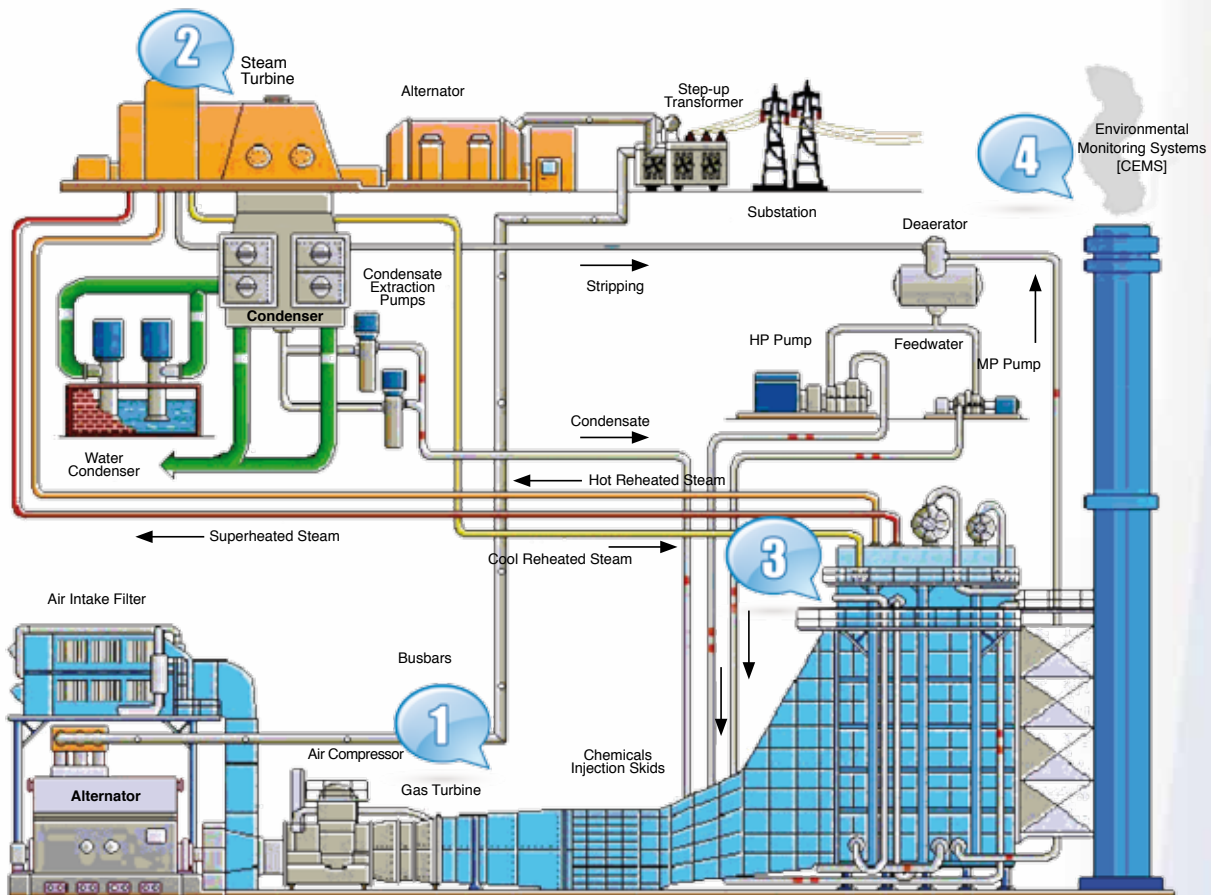

## 1. GAS TURBINE

- Metering Skid
- Analysis Skid
- Gas Reduction kid

## 2. STEAM TURBINE

- Supervisory Control System (Vibration Monitoring)
- Turbine speed control
- Electrical and Instrumentation Bulk Materials

## 3. HSRG - HEAT RECOVERY STEAM GENERATOR

- Chemicals Injection Skids  
*(Corrosion Inhibitor, Scale Inhibitor - Demulsifier, Pour Point Depressant, Antifoam, Methanol, Glycol, DRAG Reducing Agent)*
- Electrical and Instrumentation Engineering
- Electrical and Instrumentation Bulk Materials
- Water Analysis for Feedwater

## 4. THERMAL CYCLE AND AUXILIARY SERVICES

- Electrical, Instrumentation and Process Engineering
- DCS and PLC Control Systems
- IEC 61508-61511 Certified ESD Safety Systems
- Filtration, Metering, Analysis and Gas Reduction Skids
- Continuous Environmental Monitoring Skids (CEMS)
- Electrical and Instrumentation Bulk Materials.

## ANALYZER SYSTEMS:

- Analyzer Shelter Packages
- Environmental Monitoring Systems (CEMS)
- Sampling Systems
- Sampling Conditioning Systems
- Sampling Conditioning Water Systems
- Oil in Water Monitoring Systems
- Gas Analyzer Systems

## SKIDS & PACKAGES:

- Fuel Gas Train Treatment Skids  
*(ESD, Filtration, Metering, Analysis, Heater, Reducing)*
- Gas Pressure Reducing Stations and Final Filtering for Gas Turbine
- Gas Pressure Reducing Stations for Auxiliary Boilers
- Gas Odorizer Systems
- Chemical Dosing Systems for Water Treatment
- Steam Cycle and Water Treatment *(Raw Water treatment, Make-up Water Tower, Desalination, Potabilization, Waste, Biological)*
- Chemical Dosing Systems for Cooling Water Towers  
*(Biocide, Biodispersant Sodium, Hypochlorite, Sulphuric acid, Oxygen Scavenger)*
- Nitrogen Production Packages: Membrane & PSA
- Instrument and Service Air Packages
- Trucks and Rail Tankers Arm Loading Systems
- Hydrogen Generation Packages
- Diesel Power Generation Packages
- Water Treatment Packages *(Primary & Secondary Water Biological)*
- Fire Fighting Packages

# Material & Services that ECISGROUP supplies:

Environmental Monitoring Systems (CEMS)

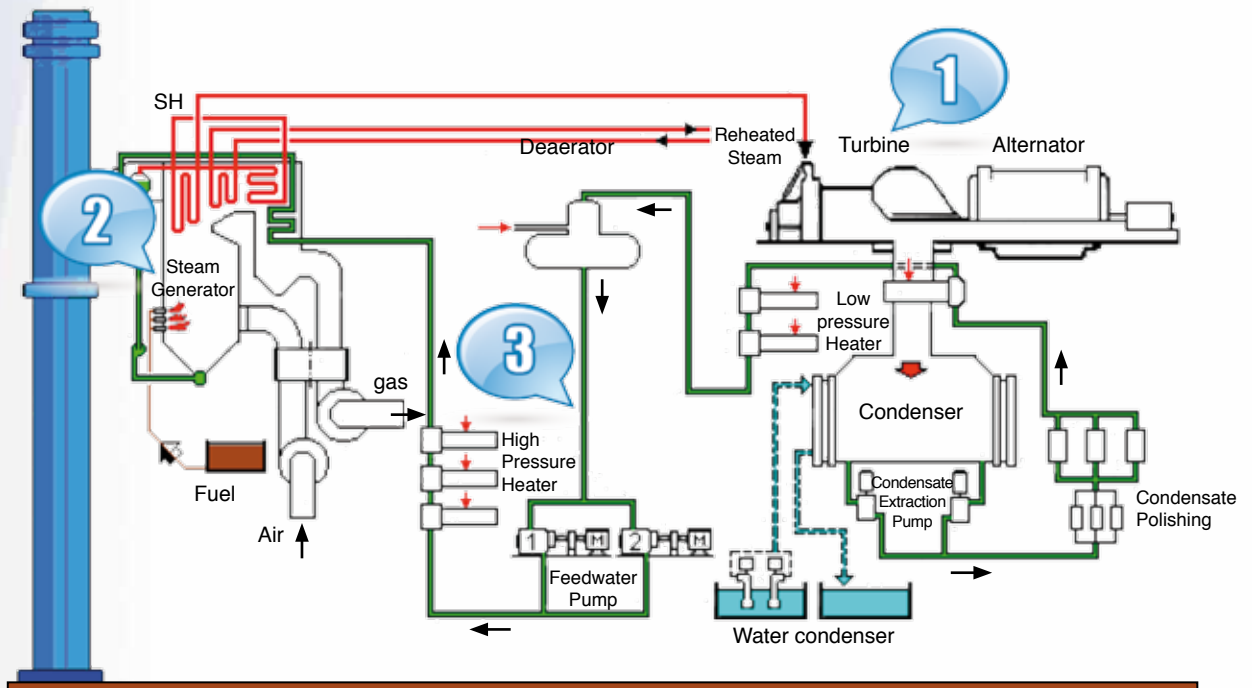

### 1. STEAM TURBINE

- Supervisory Control System [Vibration Monitoring]
- Turbine speed control
- Electrical and Instrumentation Bulk Materials

### 2. BOILER

- Burner Management Systems/ Boiler Protection Systems
- Blower Control Systems
- Electrical and Instrumentation Engineering
- Water Analysis for Feedwater

### 3. THERMAL CYCLE AND AUXILIARY SERVICES

- Electrical, Instrumentation and Process Engineering
- DCS and PLC Control Systems
- IEC 61508-61511 Certified ESD Safety Systems
- Chemicals Injection Skids (Corrosion Inhibitor, Scale Inhibitor - Demulsifier, Pour Point Depressant, Antifoam, Methanol, Glycol, DRAG Reducing Agent)
- Filtration, Measuring, Analysis and Gas Reduction Skids
- Environmental Monitoring Systems [CEMS]
- Electrical and Instrumentation Bulk Materials

### ANALYZER SYSTEMS:























































- Analyser shelters
- Continuous Environmental Monitoring Skids (CEMS)
- Sampling Systems
- Sample Conditioning Systems
- Water Sample Conditioning Systems
- Oil in Water Monitoring Systems
- Gas Analyzer Systems

### SKIDS & PACKAGES:

- Fuel Gas Train Treatment Skids (Filtration, Metering, Analysis, Heating, Reducing)
- Gas Pressure Reducing Stations
- Final Filtering for Gas Turbines
- Gas Odorizer Systems
- Chemical Dosing Systems for Water Treatment
- Steam Cycle and Water Treatment (Raw Water Treatment, Make-up Water, Water Tower, Desalination, Potabilization, Waste Water Treatment, Biological Water Treatment)
- Chemical Dosing Equipment for Cooling Tower Water (Biocide, Biodispersant, Sodium, Hypochlorite, Sulphuric Acid, Oxygen Scavenger)
- Nitrogen Generators, Pressure Swing Adsorption (PSA)
- Instrument and Service Air Generation Packages
- Truck and Rail Tanker Loading Systems
- Hydrogen Generation Packages
- Diesel Engine Power Generation Units
- Water Treatment Packages (Primary and Secondary Water, Biological)
- Fire Fighting Packages



## Automation POWER References

CUSTOMER	END USER	PROJECT	DESCRIPTION	YEAR	
		ENI E&P REFINERY POWER STATION GELA <b>ITALY</b>	SUPPLY, INSTALLATION, ENGINEERING, COMMISSIONING & START - UP OF ESD SYSTEM FOR BOILER 100 POWER STATION	2011	
		THERMOELECTRIC POWER PLANT FEDERICO II° BRINDISI <b>ITALY</b>	SUPPLY, INSTALLATION, ENGINEERING, COMMISSIONING & START - UP OF DCS SYSTEM FOR "MIXED BEDS"	2010	
		THERMOELECTRIC POWER PLANT NORTH BRINDISI <b>ITALY</b>	SUPPLY, INSTALLATION, ENGINEERING, COMMISSIONING & START - UP OF POWDEX GR 3-4 AND "MIXED BEDS"	2010	
	SORGENIA	COMBINED POWER PLANTS GISSI, SCANDALE, MODUGNO <b>ITALY</b>	SUPPLY, INSTALLATION, ENGINEERING, COMMISSIONING & START - UP OF N°6 ESD SYSTEMS SIL.3 IEC 61508	2009 2008 2007	
		IES MANTOVA REFINERY, <b>ITALY</b>	SUPPLY, INSTALLATION, ENGINEERING, COMMISSIONING & START - UP OF DCS & BMS SYSTEMS FOR REFINERY POWER STATION	2009 2008 2007	
		THERMOELECTRIC POWER PLANT, FUSINA <b>ITALY</b>	SUPPLY, INSTALLATION, ENGINEERING, COMMISSIONING AND START-UP OF N°2 ESD SYSTEMS SIL.3 IEC 61508	2009	
	EL KUREIMATH	COMBINED POWER PLANT <b>EGYPT</b>	SUPPLY, INSTALLATION, ENGINEERING, COMMISSIONING & START - UP OF BOP PLC SYSTEM	2008	
		POWER PLANT, TEVEROLA <b>ITALY</b>	SUPPLY, INSTALLATION, ENGINEERING, COMMISSIONING & START -UP OF DCS AND ESD SYSTEMS	2008 2007	
	CEPC / CAIRO NORTH	COMBINED POWER PLANT <b>EGYPT</b>	SUPPLY, INSTALLATION, ENGINEERING, COMMISSIONING & START-UP OF BOP PLC SYSTEM	2006	
		COMBINED POWER PLANT, FERRARA <b>ITALY</b>	SUPPLY, INSTALLATION, ENGINEERING, COMMISSIONING & START-UP OF ESD SYSTEMS. DCS OVATION SW IMPLEMENTATION	2006	
		POWER PLANT LOMELLINA <b>ITALY</b>	SUPPLY, INSTALLATION, ENGINEERING, COMMISSIONING OF DCS AND ESD SYSTEMS	2006	
		POWER PLANT HEATING CREMONA <b>ITALY</b>	ENGINEERING, COMMISSIONING AND START-UP OF DCS SYSTEM	2006	
		COMBINED POWER PLANT TERMINI IMERESE <b>ITALY</b>	SUPPLY, INSTALLATION, ENGINEERING, COMMISSIONING AND START-UP OF N°1 ESD SYSTEM SIL.3 IEC 61508	2006	
		INCINERATOR LEGNANO <b>ITALY</b>	MODIFICATION ON YOKOGAWA DCS SYSTEM	2005	
		POWER PLANT SULCIS CAGLIARI <b>ITALY</b>	DELTA V SOFTWARE IMPLEMENTATION, COMMISSIONING & START -UP OF DCS SYSTEM	2004	
		POWER PLANT HEATING CREMONA <b>ITALY</b>	MYCRO MOORE TECHNICAL ASSISTANCE	2004	
		POWER PLANT SESTO S.G. <b>ITALY</b>	AC800 SOFTWARE IMPLEMENTATION COMMISSIONING & START -UP OF DCS SYSTEM	2003	
		THERMOELECTRIC POWER PLANT, PIETRAFITTA <b>ITALY</b>	SUPPLY, INSTALLATION, ENGINEERING, COMMISSIONING & START -UP OF DCS, ESD, FIRE & GAS SYSTEMS	2003 2002	
		COMBINED POWER PLANT TERMINI IMERESE <b>ITALY</b>	SUPPLY, INSTALLATION, ENGINEERING, COMMISSIONING & START-UP OF N°2 ESD SYSTEMS SIL.3 IEC 61508	2002	
		THERMOELECTRIC POWER PLANTS MANTOVA, BRINDISI, RAVENNA, FERRERA ERBOGNONE, <b>ITALY</b>	SUPPLY, INSTALLATION, ENGINEERING, COMMISSIONING & START-UP OF N°14 ESD SYSTEMS SIL.3 IEC 61508	2002	
		THERMOELECTRIC POWER PLANT OSTIGLIA <b>ITALY</b>	SUPPLY, INSTALLATION, ENGINEERING, COMMISSIONING & START-UP OF N°3 ESD SYSTEMS SIL.3 IEC 61508	2002	
		COMBINED POWER PLANT GR3, GR4 PORTO CORSINI <b>ITALY</b>	SUPPLY, INSTALLATION, ENGINEERING, COMMISSIONING & START-UP OF N°2 ESD SYSTEMS SIL.3 IEC 61508	2001	
		THERMO ELECTRIC POWER PLANT GR.1, GR.2, GR.3, GR4 LA CASELLA, <b>ITALY</b>	SUPPLY, INSTALLATION, ENGINEERING, COMMISSIONING & START-UP OF N°4 ESD SYSTEMS SIL.3 IEC 61508	2001	
		INCINERATOR, <b>ITALY</b>	SUPPLY, INSTALLATION, ENGINEERING, COMMISSIONING & START-UP OF DCS, ESD, BMS	2001 2000	
	SHARJAH ELECTRICITY AND WATER AUTHORITY COMPLEX AL LAYYAH AREA	LAYYAH POWER PLANT SHARJAH, <b>UAE</b>	BOILER PROTECTION AND BMS CERTIFIED SIL.3 IEC 61508	2000	

CUSTOMER	END USER	PROJECT	DESCRIPTION	YEAR
ALSTOM POWER		RIMINI PROJECT <b>ITALY</b>	TURN KEY JOB SUPPLY OF N° 1 NITROGEN BLANKETING SYSTEM	2010
CORE		URBAN SOLID WASTE INCINERATOR PLANT <b>ITALY</b>	REVAMPING OF ANALYSIS SYSTEM	2010
SARLUX		SARROCH REFINERY <b>ITALY</b>	EMISSIONS ANALYZER SHELTER	2009
TECHINT	 ENI R & M	HYDROGEN MANUFACTURING UNIT <b>ITALY</b>	TURN KEY JOB SUPPLY OF N° 1 CONTINUOUS EMISSIONS MONITORING SYSTEM ANALYZER SHELTER WITH ANALYZERS	2008
ALSTOM		30245 FORLI' PROJECT <b>ITALY</b>	TURN KEY JOB SUPPLY OF N° 1 NITROGEN BLANKETING SYSTEM	2007
ALSTOM		30245 FERRARA PROJECT <b>ITALY</b>	TURN KEY JOB SUPPLY OF N° 1 NITROGEN BLANKETING SYSTEM	2007
SNAMPROGETTI /ENIPOWER	 EniPower	COMBINED CYCLE PLANT FERRERA ERBOGNONE <b>ITALY</b>	TURN KEY JOB SUPPLY OF ANALYZER SHELTER FOR BTU MEASUREMENT OF NATURAL GAS AND SYNGAS ANALYSIS	2003
SNAMPROGETTI /ENIPOWER	 EniPower	COMBINED CYCLE PLANT RAVENNA <b>ITALY</b>	TURN KEY JOB SUPPLY OF ANALYZER SHELTER FOR BTU MEASUREMENT OF NATURAL GAS	2003
SNAMPROGETTI /ENIPOWER	 EniPower	COMBINED CYCLE PLANT BRINDISI <b>ITALY</b>	TURN KEY JOB SUPPLY OF ANALYZER SHELTER FOR BTU MEASUREMENT OF NATURAL GAS	2003
SNAMPROGETTI /ENIPOWER	 EniPower	COMBINED CYCLE PLANT MANTOVA <b>ITALY</b>	TURN KEY JOB SUPPLY OF ANALYZER SHELTER FOR BTU MEASUREMENT OF NATURAL GAS	2003
ENELPOWER	 SULCIS	HIGH PRESSURE BOILER SAMPLING AND ANALYSIS SYSTEM, <b>ITALY</b>	TURN KEY JOB SUPPLY OF N° 11 SAMPLING STREAMS EQUIPPED WITH SAMPLE TREATMENT ANALYZERS	2003
ENELPOWER	 TERMINI IMERESE	HIGH PRESSURE BOILER SAMPLING AND ANALYSIS SYSTEM, <b>ITALY</b>	TURN KEY JOB SUPPLY OF N° 32 SAMPLING STREAMS EQUIPPED WITH SAMPLE TREATMENT, ANALYZERS AND N° 1 NEW SHELTER	2003
ENELPOWER	 PRIOLO GARGALLO	HIGH PRESSURE BOILER SAMPLING AND ANALYSIS SYSTEM, <b>ITALY</b>	TURN KEY JOB SUPPLY OF N° 32 SAMPLING STREAMS EQUIPPED WITH SAMPLE TREATMENT, ANALYZERS AND N° 1 NEW SHELTER	2002
ENELPOWER	 PORTO CORSINI	HIGH PRESSURE BOILER SAMPLING AND ANALYSIS SYSTEM, <b>ITALY</b>	TURN KEY JOB SUPPLY OF N° 28 SAMPLING STREAMS EQUIPPED WITH SAMPLE TREATMENT, ANALYZERS AND N° 1 NEW SHELTER	2001

**ECISGROUP S.p.A.**  
**Head Office**

Via Pavia, 21  
Muggiò (MB) - 20835 - Italy  
Phone +39 039 27881  
Fax +39 039 2781353  
seco@ecisgroup.it  
www.ecisgroup.it

**Sede Legale:**

Via Giulini, 12  
22100 Como (CO), Italy  
Reg. Imprese di Como  
N° 03046260133  
R.E.A. CO - 292997  
C.F. / P.I. 03046260133  
Capitale Sociale 1.000.000,00 € i.v.